

1" WB NON-METALLIC Models MODEL: WB10X-XXS-XXX

SPECIFICATION:

| | | | |
|--|---------------------------------|---------------|--|
| Ratio: | 1:1 | | |
| Maximum GPM (LPM): | 53 (200) | | |
| Displacement per cycle Gallons (Liters): | 0.226 (0.86) | | |
| Air Inlet (Female): | 1/4 - 18 N.P.T. | | |
| Fluid Inlet/Outlet: | 1" A.N.S.I./DIN flange | | |
| Max. operating pressure psi (bar): | 120 (8.3) | | |
| Suspended solids max. dia. in.(mm): | 1/8" (3.2) | | |
| Weight lbs (kg): | Polypropylene, Side Ported | 19.87 (9.01) | |
| | PVDF, Side Ported | 27.15 (12.32) | |
| Maximum dry suction lift ft(m) : | 19 (5.7) | | |
| Sound Level: | 70 PSI 60 Cycles/Min 79.7 db(A) | | |

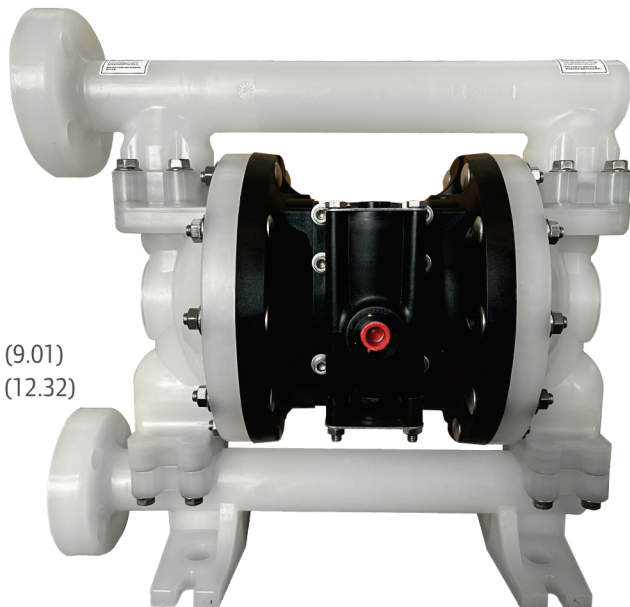

MODEL DESCRIPTION & ORDERING:

| Position | 1 | 2 | | 3 | 4 | 5 | | 6 | 7 | 8 | | | |
|----------|-------------|----------|---|----------|----------|----------|---|----------|----------|----------|--|--|--|
| Example: | WB10 | X | - | X | X | S | - | X | X | X | | | |

| Position 1 Model Series | Position 2 Center Section | Position 3 Connections | Position 4 Wetted Parts | Position 5 Hardware | Position 6 Seat Material | Position 7 Ball Material | Position 8 Diaphragm Material | |
|----------------------------|---|-----------------------------------|--|------------------------|--|---|--|--|
| WB10 - Standard Pump | E - Conductive Polypropylene P - Polypropylene | F - 1" A.N.S.I./DIN Flange (Side) | E - Conductive Polypropylene* K - PVDF P - Polypropylene | S - SS | H - 440 SS (Hard) K - PVDF P - Polypropylene S - 316 SS | A - Santoprene® C - Hytrel® G - Nitrile T - PTFE V - Viton® | A - Santoprene® C - Hytrel® G - Buna-N L - Long-Life PTFE M - Med. Grade Santoprene® T - PTFE/Santoprene® V - Viton® | |

Hytrel® and Viton® are registered trademarks of the DuPont company. Santoprene® is a registered trademark of Monsanto Company, licensed to Advanced Elastomer Systems, L.P.

Accessories

Service Repair Kits:

AIR MOTOR FOR WB10P: WB637397;

FLUID SECTION: WB637396-XX;

MAJOR AIR VALVE ASSEMBLY: WB637395-X;

1" WB NON-METALLIC Models MODEL: WB10X-XXS-XXX

DIMENSIONS:

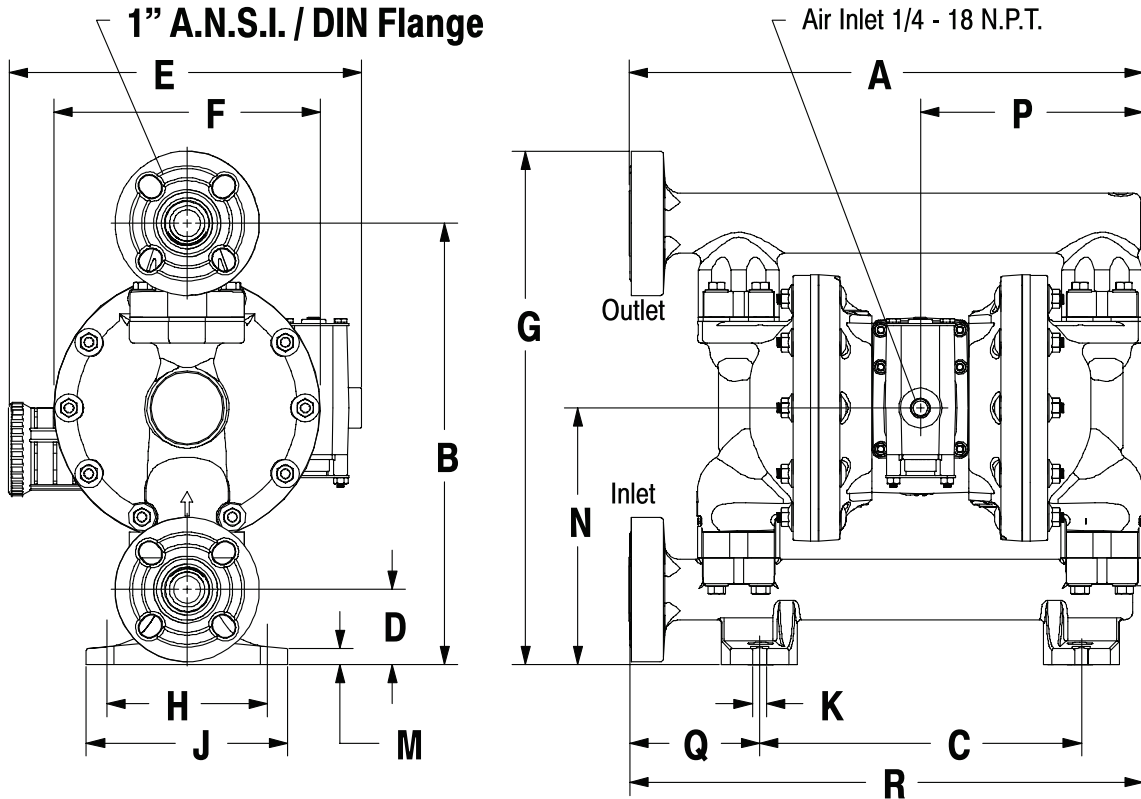

- E: 11-1/32"(279.5mm)
- F: 8-5/16"(211.1mm)
- B: 13-25/32"(349.8mm)
- D: 2-11/32"(59.4mm)
- M: 1/2"(12.7mm)
- H: 5-1/32"(127.6mm)
- J: 6-9/32"(159.6mm)

- A: 16-1/32"(407.3mm)
- P: 6-31/32"(176.6mm)
- G: 16-1/32"(407.3mm)
- N: 8-1/32"(203.4mm)
- K: 7/16"(11.1mm)
- Q: 4-1/16"(103mm)
- C: 10-1/16"(255.3mm)
- R: 16-1/32"(407.3mm)

PERFORMANCE CURVE:

